

OPERATION MANUAL



PANDORA-1D/2D/3D MULTI P.A COMBINATION AMPLIFIER



Unpacking and Installation

Although it is neither complicated to install nor difficult to operate your set , a few minutes of your time is required to read this manual for a properly wired installation and becoming familiar with its many features and how to use them.

Please take a great care in unpacking our set and do not discard the carton and other packing materials. That may be needed when moving your set and are required if it ever becomes necessary to return your set for service. Never place the unit near radiators, in front of heating vents, excessive humid or dusty location to avoid early damage and for your years quality use. Connect your complementary component as illustrated in the following page.

 <p>CAUTION RISK OF ELECTRIC SHOCK DO NOT OPEN</p>	 <p>This symbol is intended to alert the user to the presence of uninsulated "dangerous voltage" within the product's enclosure that may be of sufficient magnitude to constitute a risk of electric shock to persons.</p>
<p>CAUTION : TO REDUCE THE RISK OF ELECTRIC SHOCK. DO NOT REMOVE COVER (OR BACK). NO USER-SERVICEABLE PARTS IN SIDE. REFER SERVICING TO QUALIFIED SERVICE PERSONNEL.</p>	 <p>This symbol is intended to alert the user to the presence of important operation and maintenance (servicing) instructions in the literature accompanying the appliance.</p>
<p>WARNING</p>	<p>Caution : To prevent electric shock do not use this (polarized) plug with an extension cord, receptacle or other outlet unless the blades can be fully inserted to prevent blade exposure.</p>
<p>To prevent fire or shock hazard, do not expose the unit to rain or moisture.</p>	<p>Attentions : Pour prevenir les chocs electriques ne pas utiliser cette fuche polarisee avec un prolongateur, une prise de courant on une autre soruie de courant, sauf si les lames peuvent etre inserees a fond sans en laisser aucune partie a decouvert.</p>

Features

● SPEAKER SELECTOR

Eleven-speaker selector switches allow you to select up to 10 speakers in any combination.

● VERSATILE AND EASY TO USE

Incorporating all the necessary system components to provide versatility in an easy to use form : eleven channels of input signals (MIC 1~5, AUX 1 ~2, TUNER, DVD, DECK, REMOTE), four tone chime, 7 band equalizer and 10 channels speaker selector.

● CHANNEL PRIORITY AND MUTING

MIC1, 2 and four tone chime have priority over the other input signals. The muting level is adjustable from the rear panel of the unit. (Telephone paging > REMOTE > MIC1, 2, Chime)

● 7 BAND EQUALIZER

7 band graphic equalizer gives you unlimited tone control, allowing you to shape your sound to meet your environment.

● USB INTERFACE FUNCTION

USB storage media and external HDD can use. (MP3 files and AVI files can play.)

● VARIOUS MEDIA POSSIBILITY

Audio CD, HDCD, DVD, VCD, MP3CD, SVCD, AVI, JPG format file CD, CD-R, CD+R, CD+RW, DVD-R, DVD+R, DVD-RW various media can play.

● FULL LOGIC AUTO-REVERSE CASSETTE DECK

Full logic dual cassette deck provides auto-reverse for continuous playback.

Auto-relay function also provides cascading playback between Deck A and Deck B for seamless continuous playback.

● SIDE PANEL MONITOR SPEAKER







Side-mounted monitor speaker with three-position switch allows you to monitor the system's output.

● ANNOUNCEMENT CHIME

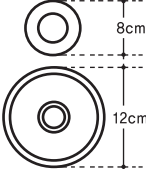
Convenient two/four tone chime for use with announcement.

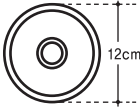
MULTI P.A COMBINATION AMPLIFIER

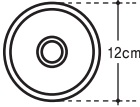
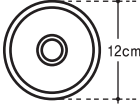
Playback Disc Type

DISK	DIMENSION	LABEL
DVD		
SVCD CVD		
KODAK PICTURE CD		
MP3		MP3
HDCD		
video - CD(VCD)		
JPEG, MPEG, AVI DIVX, XVID		

Handling the Discs

1. Always place the disc in the disc tray with the label facing upward.
2. To remove a disc from its storage case, press down on the center of the case and lift the disc out, holding it carefully by the edges.
3. Finger marks and dust should be carefully wiped off the disc's recorded surface with a soft cloth.
4. Never use such chemicals as record sprays, antistatic sprays or fluid, benzene or thinner to clean discs. Such chemicals will do irreparable damage to the disc's plastic surface.
5. Do not expose discs to direct sunlight or high humidity and temperature for extended periods. Long exposure to high temperatures can warp the disc.

2. PANDORA-1D/2D/3D

Front Panel Controls

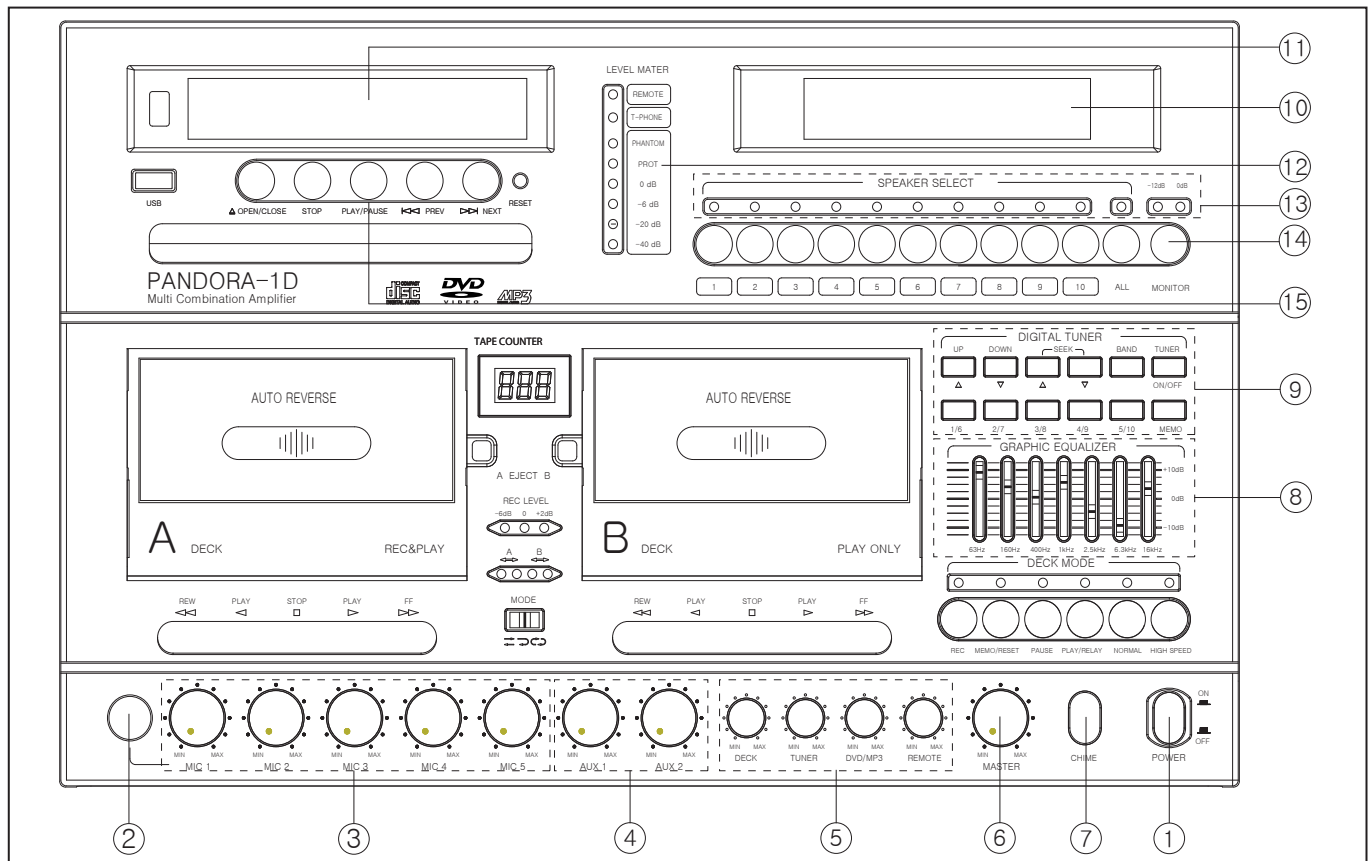

1. POWER SWITCH

Pressing this button switches the unit on. Pressing the button again will switch the unit off.

2. MIC 1 INPUT

Input jack for MIC 1.(Note. Mic 2–5 are located on the rear panel.)

3. MIC INPUT LEVEL CONTROL

Controls the individual levels of mic inputs 1 through 5.

4. AUX VOLUME

Controls the level of Aux 1 and Aux 2 inputs.

5. DECK/TUNER/DVD,MP3/REMOTE LEVEL CONTROL

Controls the level of DECK/TUNER/DVD,MP3/REMOTE.

MULTI P.A COMBINATION AMPLIFIER

6. MASTER VOLUME

This knob provides continuous control of the overall system output volume.

7. CHIME BUTTON

Pressing this switch activates the chime circuitry.

8. GRAPHIC EQUALLIZER

Each slider controls the cut(decreased gain) or boost(increased gain) for its associated frequency band. The middle position indicates flat response (no cut or boost). Moving the slider upwards increases the frequency's gain, while moving it down decreases the level of the frequency.

9. TUNER SECTION

Radio tuner operating section.

10. RADIO TUNER VFD DISPLAY

You can confirm the working status of tuner through this display.

11. DVD VFD DISPLAY

This vfd display indicates the status of the DVD/USB unit.

12. LED INDICATOR

PHANTOM(Condencor Mic power), PROTECTION , Output Level (CLIP, -6dB, -20dB, -40dB), Telephone-Paging, REMOTE AMP(DRA-9600) Connection.

★ PROT (PROTECTION INDICATOR)

When the Protection LED ON, THE PROTECTION Circuitry is active, indicating that the unit is not operating normally. This is typically due to overheating or power limiting. Please check the input and output condition of the amplifier.

13. SPEAKER SELECT LED

These LEDs indicate the activated speaker.

14. SPEAKER SELECTOR

These swithes are used to individually select audio output to any combination of up to 10 speakers.

15. DVD SECTION

Optical Disc(DVD, VCD, etc,.) and USB operating section.

4. PANDORA-1D/2D/3D

Rear Panel Controls

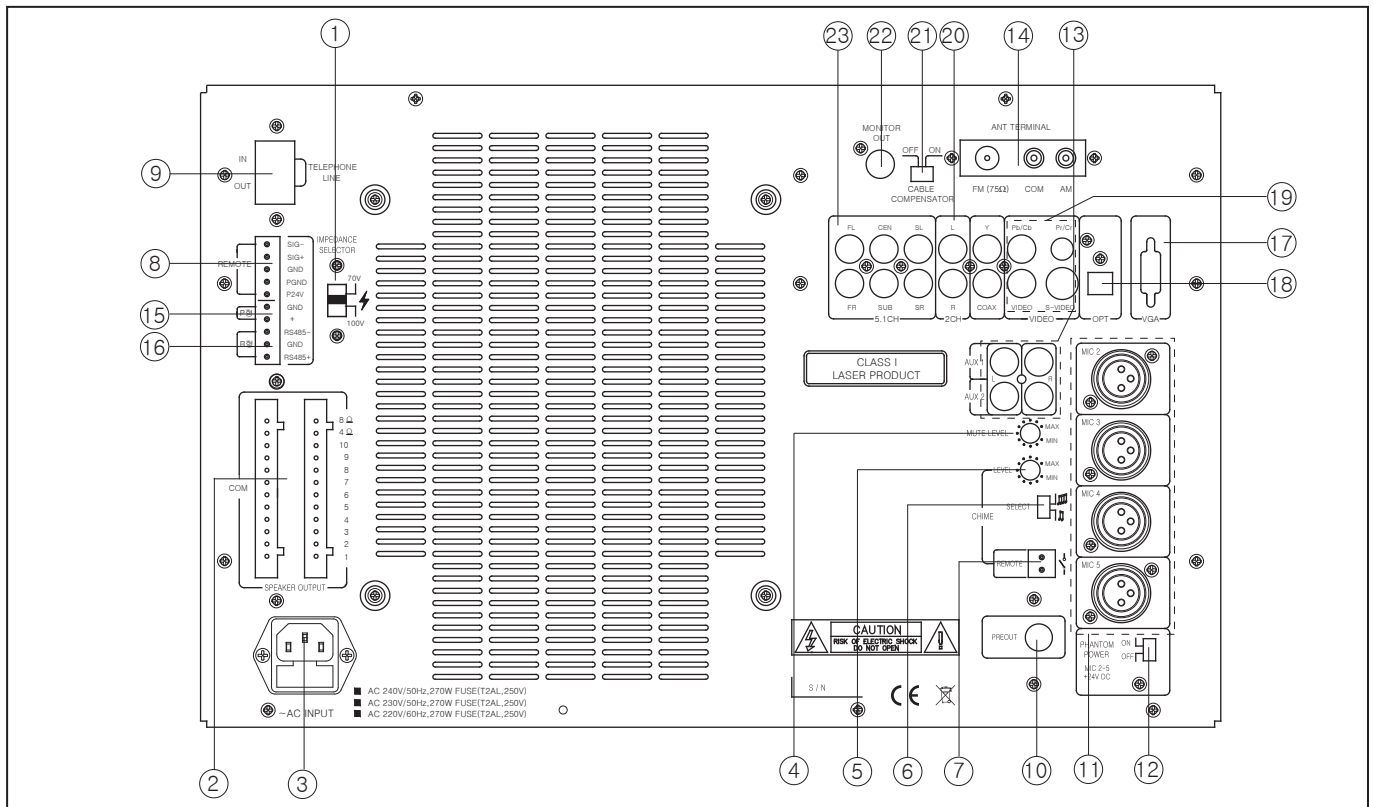

1. IMPEDANCE SELECTOR

Selects between high impedance(100V) and high impedance(70V).

2. SPEAKER OUTPUT TERMINAL STRIP

Connect up to 10 individual speakers to this strip. Make certain that the total impedance is less than the rated impedance.

3. AC INLET

Connect the supplied standard AC input cable here.

4. MUTE LEVEL CONTROL

Controls the MUTE Level(MIC 1/2).

5. CHIME VOLUME

Controls the CHIME Level.

6. CHIME TONE SELECTOR

Selects 2 tone or 4 tone chime.

MULTI P.A COMBINATION AMPLIFIER

7. REMOTE CHIME

When this terminal is shorted by wired remote, the chime circuitry is activated.

8. REMOTE AMP (DRA-9600)

By connecting REMOTE AMP(DRA-9600), It is possible to control speaker zone selection and activate chime circuitry.

9. TELEPHONE INPUT TERMINALS

These terminals can be connected to telephone exchange system for paging purpose.

Note. : When an active signal is sent through the telephone input, all other input signals are muted.

10. PREOUT

This output provides line level output signal for connection to an external amplifier.

11. MIC INPUT 2-5

Connect Mic input 2~5 here. Phantom power is available.

12. PHANTOM POWE SWITCH

This switch turns the phantom power supply on or off for Mic 2~5. When the switch is turned on, +15V DC power is supplied to pins 2 and 3 of each channel's input connector.

13. LINE INPUT(AUX)

This line level input is an external stereo input for a stereo source.

The input level is -10dB (300mV).

14. ANTENNA TERMINALS

- FM RECEIVING ANTENNA : 75Ω coaxial cable antenna.

- AM RECEIVING ANTENNA : 300Ω loop antenna.

15. FIRE RECEIVER PORT

This is for connection P-type Fire Receiver.

6. PANDORA-1D/2D/3D

16. FIRE RECEIVER PORT

This is for connection R-type Fire Receiver.

DATA FORMAT : RS-485/ 9600bps/ N/ 8/ 1

17. VGA OUTPUT

Connected to PC monitor.

18. DIGITAL AUDIO OUTPUT

Connected to OPTICAL interface.

19. VIDEO OUTPUT TERMINALS

These terminals are for VIDEO OUT(COMPONENT, COMPOSITE, S-VIDEO).

20. (AUDIO(STEREO) OUTPUT

This output provides line level output signal(stereo) for connection to an external amplifier.

21. VIDEO COMPENSATION SWITCH

By turning this switch on, it compensates the loss of output level for long distance cable.

22. VIDEO SIGNAL OUTPUT(COMPOSITE)

The video signal is sent through this terminal. It is connected to VCR, Monitor, etc.

23. AUDIO OUTPUT(5.1 CH)

Connected to 5.1 channel analog system(Home Theater).

MULTI P.A COMBINATION AMPLIFIER

■. Optical Disc/USB

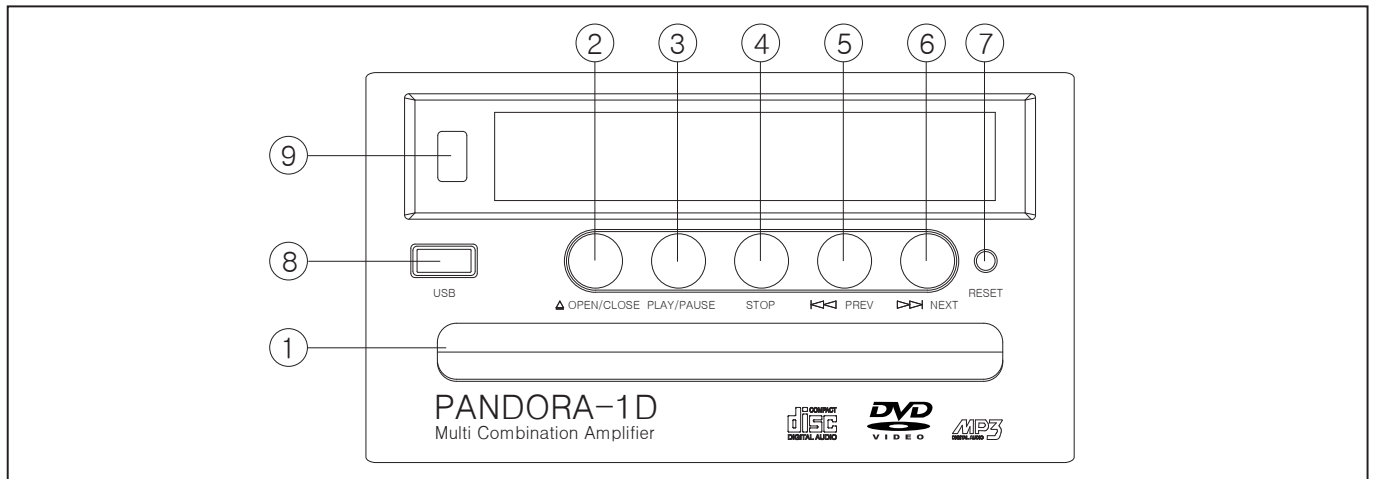

1. DISC TRAY

The place to put the DISC into.

2. OPEN/CLOSE BUTTON

To change a DISC when opening or closing the tray.

3. PLAY/PAUSE BUTTON

Use this button to play DISC. If you press "PLAY" button twice, it becomes "PAUSE" state, and press it once more it plays again.

4. STOP BUTTON

To stop all function while playing DISC.

5. PREV BUTTON

Move to the previous track from the current track of DISC.

6. NEXT BUTTON

Move to the next track from the current track of DISC.

7. RESET BUTTON

Initialize a video output mode that is set related with DVD playback.

8. Linkage Terminal of a USB storage device

Use it by connecting with a USB storage device or a mass USB storage device(HDD). It is possible to recognize as dividing into 40Gbyte, FAT32 in case of a mass USB storage device(HDD).

9. REMOTE CONTROL Receive Part

This is an infrared light receive part of the remote control that controls DVD.

● REMOTE CONTROLLER

- ① **Power On/Off**
- ② **Video mode selector(Composite, Component, S-Video, VGA)**
- ③ **TV system mode selector (NTSC, PAL)**
- ④ **Open/close CD tray**
- ⑤ **REPEAT : One or all Track**
A-B : Repeat section
RANDOM : Select and play randomly
USB/DVD : Select button
- ⑥ **LANGUAGE : Voice language select**
SUBTITLE : Caption language select
ANGLE : Convert the angle of DVD image
R/L : Right/left selector for output
- ⑦ **REW : Rewind track during playback**
FWD : Forward track during playback
PREV : Move to previous track
NEXT : Move to next track
SETUP : Setup system preference
MENU : Display DVD menu during playback
- ⑧ **Move or select the menu title**
PBC : Display index of tracks in VCD
TITLE : Display index of tracks in DVD
- ⑨ **ZOOM : Enlarge or downsize the image in play**
PLAY/PAUSE : to play or pause
STOP : Stop playing
RETURN : stop playback and move back to previous menu
SLOW : Play image slowly
STEP : Play video by scene
PROG : sort playlist by the title, chapter, or music
- ⑩ **1~10 : Select track to play.**
TIME : Displays proceeding/remaining time in current play.
- ⑪ **OSD : Display caption on TV in configuration**
MUTE : Mute/unmute sound
VOL + - : Controls the volume

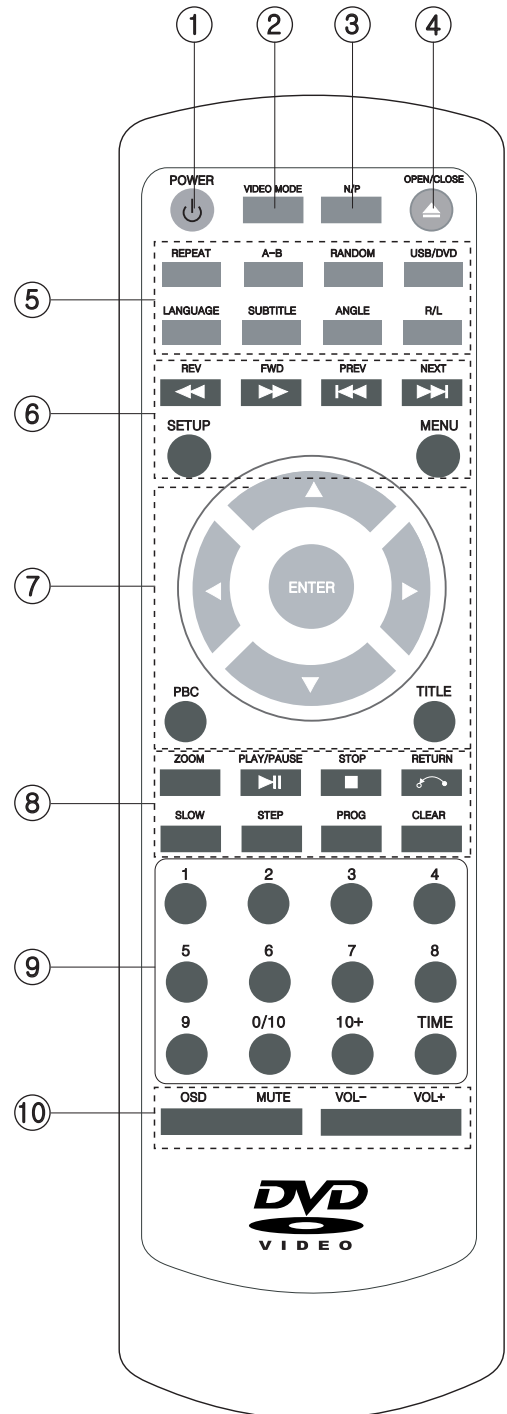

MULTI P.A COMBINATION AMPLIFIER

● How to use DVD, CD DISC

Available types of media and usage

– DVD, DVD-R, DVD+R, DVD_RW, CD, HDCD, CD-R, CD+R, CD_RW, MP3 CD, AVI CD, JPG CD

- ① Open the tray using the OPEN/CLOSE button, and press the OPEN/CLOSE button after putting CD or DVD into the tray.
- ② If CD or DVD aren't on the tray or there is some problem, the screen shows "NO DISC"
- ③ Play CD or DVD as pressing the PLAY/PAUSE button.
- ④ If you press the PLAY/PAUSE button during playing, it will pause.
- ⑤ If you press the STOP button once during playing, CD or DVD will stand by in the PRE STOP state.
- ⑥ By pressing the PLAY/PAUSE button in the PRE STOP state, CD or DVD replay and they stop completely by pressing the STOP button.

– In case DISC is already on the tray when you power on

- ① It reads the track on the DISC.
- ② After selecting the desired DISC, operate by pressing the PLAY button.

PLAY Function

- ① After inserting a DISC, press the PLAY button.
- ② Start playing the DISC.
- ③ By pressing the REPEAT button of the remote control, the selected track will be played back repeatedly.
OFF ----> Repeat one ----> Repeat All ----> OFF
- ④ By using the A-B button of the remote control, a designated section will be repeated.
Repeat OFF ----> Repeat A- ----> Repeat A-B ----> Repeat OFF
- ⑤ Finish the playing when all music has played.

Repeat Function

– Become the repeat function by pressing the REPEAT button of the remote control while playing CD or DVD.

- ① When starting
The repeat function is OFF state. Operate it by pressing the PLAY button.
- ② During a general operation
The repeat function operates by pressing the REPEAT button.
OFF ----> Repeat one ----> Repeat All ----> OFF ---->
- ③ REPEAT ONE
☞ The selected track will be played back repeatedly.
- ④ REPEAT ALL
☞ All music of the inserted disc will be played back repeatedly.

A-B Section-Repeat Function

– By designating the area of section-repeat using the A-B button, it plays the designated section repeatedly.

① When starting

Operate by pressing the PLAY button.

② During a general operation

Designate by pressing the A-B button at the start point of the repeat section.

Designate by pressing the A-B button at the end point of the repeat section.

☞ – Repeat Cancel ----> set A point(press A-B button) ---->
set B point(press A-B button) ----> A-B Repeat....

RANDOM Function

– Select and play a music of the inserted disc at discretion by pressing RANDOM button.

SEARCH Function

– Wind faster forward or backward by pressing the SEARCH button ◀◀,▶▶ during playback.

☞ The winding speed is adjusted by X2, X4, X8, X20 in speed unit as pressing this button once.

STEP Function

–A movie changes to a pause picture by each scene as pressing the STEP button once while playing DVD movie.

SLOW Function

–A movie changes to a pause picture by each scene as pressing the SLOW button while playing DVD movies.

☞ It is adjusted by 1/2, 1/3, 1/4, 1/5, 1/6, 1/7 in 6 step as pressing the SLOW button.

ZOOM Function

– Enlarge/Reduce the picture screen by pressing the ZOOM button while playing DVD movies.

☞ It is adjusted by zoom2, zoom3, zoom4, zoom1/2, zoom1/3, zoom1/4 in 6 step as pressing the SLOW button.

● How to operate USB

– MP3 Play

To recognize the USB device, there shouldn't be CD or DVD on the disc tray.

You can use a USB storage device and an exterior hard disc as the compatible USB device, and the partition should be formatted by FAT32. In case of an exterior hard disc, it is possible to recognize after separating the partition in 40Gb unit and formatting to FAT32. When using an exterior hard disc, recommend you the product in 3.5 inches that supports its own power supply to the exterior hard disc.

In case of the product in 2.5 inches, if the power consumption is larger than the supply power, the recognition doesn't become occasionally.

– AVI Movie File Play

It is possible to play a DVIX movie file of AVI form. Depend on the capacity and resolution of file, the playback might not play or might stop.

– JPG Photo File Play

It is possible to play a photo file of JPG format.

■ TUNER

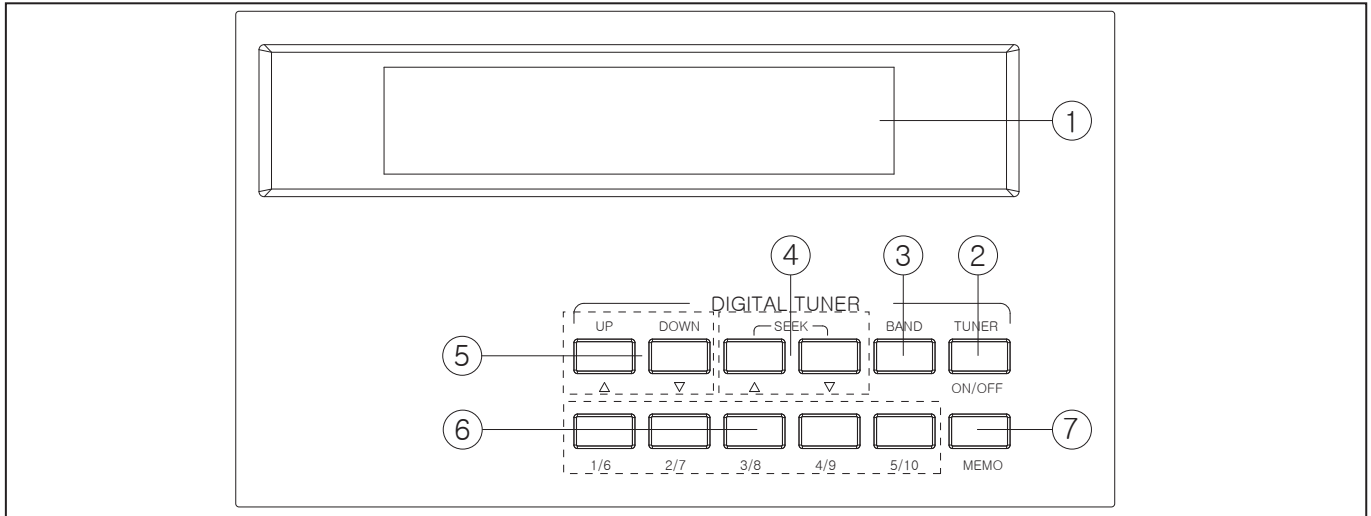

1. TUNER display screen

It shows the information of RADIO TUNER.

2. TUNER/DVD Button

To change TUNER and DVD function, ON/OFF changes by turns TUNER and DVD as pressing the button once.

3. BAND BUTTON

Use this button to listen by changing AM or FM broadcasting.
It is changed in order of FM1-2-3-AM1-2-3 as pressing the button once.

4. SEEK BUTTON

By pressing this button, frequencies that are available to listen are searched automatically.

5. FREQUENCY UP/DOWN Button

This button is used for when you set a desired broadcasting.

6. Address Select Button

There are 10 numbers from 1 to 10, you can save totally 60 address of FM, AM.
From 6 to 10, press a right number longer than usual.

7. MEMO BUTTON

Use to remember the frequency of the broadcasting station. After tuning the desired frequency press the MEMO button. And then, press a button between 1 and 6 so that the listening broadcasting frequency is saved in the selected number.

ex) When you want to save FM89.1MHz to the number 1.

- After pressing the MEMO button after setting FM89.1MHz by the FREQUENCY UP/DOWN Button press the button "1" to save FM 89.1MHz in the number 1.

MULTI P.A COMBINATION AMPLIFIER

■ CASSETTE DECK

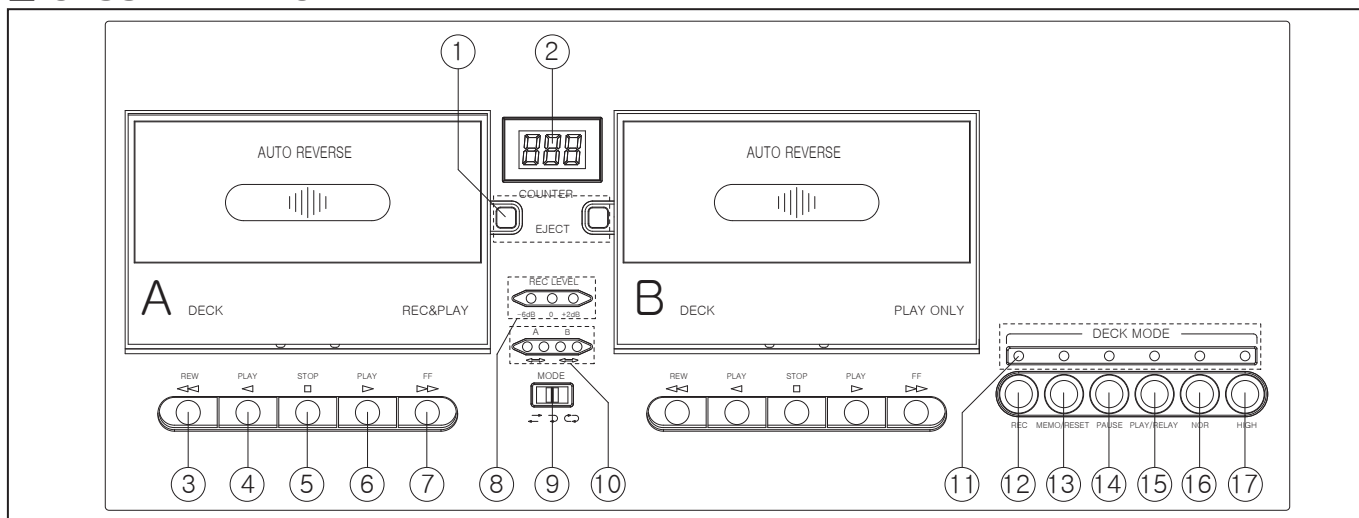

1. OPEN Button (EJECT)

Press the button, cassette door is open as smooth.

※ Do not open when the unit is operating.

2. COUNTER

You can see to proceeding level of tape.

3. Fast Rewind Button (◀◀)

To fast rewind play back to(←)direction.

4. Play - back Button (◀) (B Section)

To play - back B section of tape.

5.STOP Button (■)

To stop the tape recording.

6. Play - back Button (▶)

To play - back A section of tape.

7. Fast Forward Button (▶▶)

To fast forward play back to(→)direction.

8. RECORDING LEVEL INDICATOR

These led meters indicate the record input level.

9. MODE Switch

↔ : Play - back recording with A or B section.

↪ : Stop after from A section to B play - back.

↻ : On continuous play - back.

10. Proceed Direction Indicated Indicator LED

Indicated indicator LED as proceed direction of the tape.

11. DECK STATUS LED

Indicates the REC, MEMO, PAUSE, PLAY/RELAY, NOR, HIGH.

12. Record Button

Record ready level when turn on the Record button.

13. MEMO/RESET Button

Turn on the MEMO/RESET button, counter lettering is "000" level that level of present is memory.

14. PAUSE Button

A moment stop when turn on the button on recoding or play - back.

15. RELAY/PLAY Button (RELAY/PLAY)

On relay/play A deck to B deck.

16. NORMAL Copy Button (NOR)

Turn on the Normal button, normal copy B deck to A deck as like normal level high speed level.

17. HIGH Speed Copy Button (HIGH)

Turn on the HIGH button, normal copy B deck to A deck as like

MULTI P.A COMBINATION AMPLIFIER

● Operating the Cassette Deck

– AMS

AMS(Automatic Music Search) will locate the beginning of an audio section on a cassette tape.

To use AMS, press the FAST FORWARD or REWIND button during playback. The deck will scan to the next selection.

Note that AMS may detect a particularly quiet passage as the beginning of a new selection. If this occurs, simply press the FAST FORWARD or REWIND button again to continue scanning.

– DUBBING

Insert a pre-recorded cassette into Deck B.

Insert a blank cassette into Deck A.

For normal speed dubbing, press the REC button first and adjust the record level with the LEVEL control.

Then press the NOR DUB button for normal speed dubbing.

For high speed dubbing press the HI DUB button.

It is not necessary to adjust the record level in high speed mode, as the record level is set to the level of the source tape.

High speed dubbing copies at 1.5 times normal speed. We recommend normal speed dubbing for best audio quality. Press the STOP button to stop dubbing.

– RECORDING

Insert a blank recordable cassette into Deck A.

Select the desired source (CD, Tuner, etc.) with the Function Selector switch.

Select the desired Auto Reverse mode using the REVERSE MODE selector.

a.  :Single-side REC(Tape stops when reaching the end.)

b.  :Side A to Side B to STOP, Side B to STOP(Tape records until end of side B is reached).

Maintenance of Cassette Deck

CLEANING OF HEADS AND TAPE PATH

Generally, it is sufficient to clean heads after every 10 hours of operation, However, all surfaces over which tape travels should be cleaned before making high quality recordings.

1. Set the POWER switch to OFF and remove cassette door lid by pushing it up and then taking it out toward the front side after opening the door.

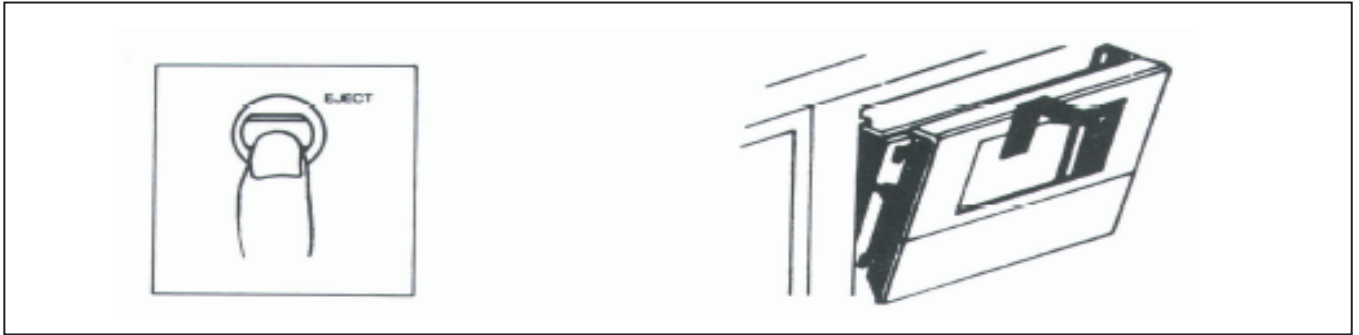

2. Wipe the heads using a cleaning tip slightly moistened with commercially available head cleaner.

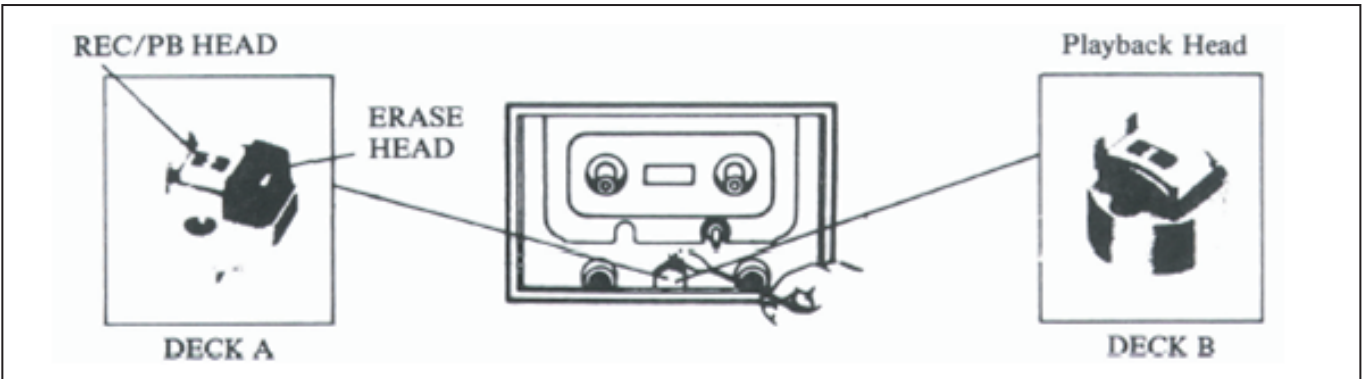

3. Wipe the capstan and pinch roller using another cleaning tip slightly moistened with the commercially available rubber cleaner.

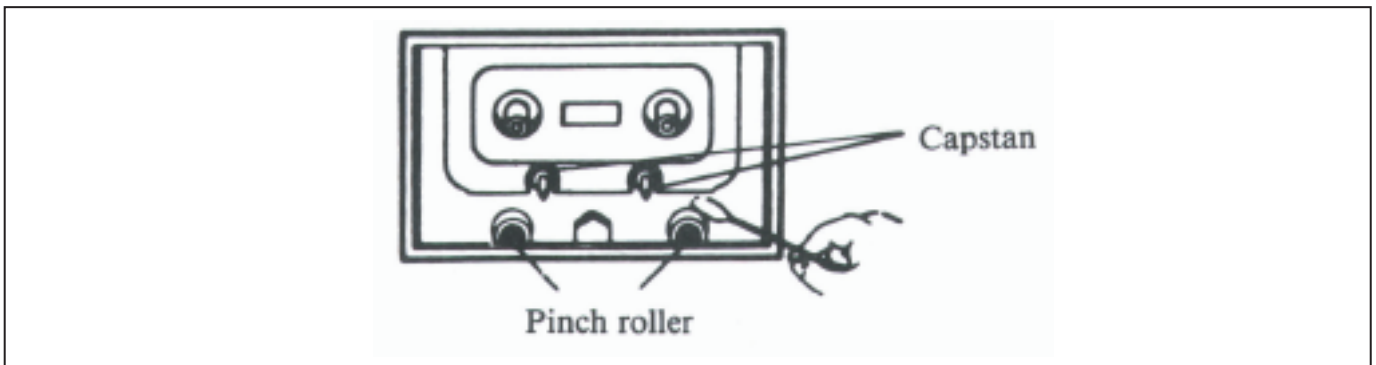

4. Replace the door lid.
 - Do not insert cassette until the cleaner dries out.

MULTI P.A COMBINATION AMPLIFIER

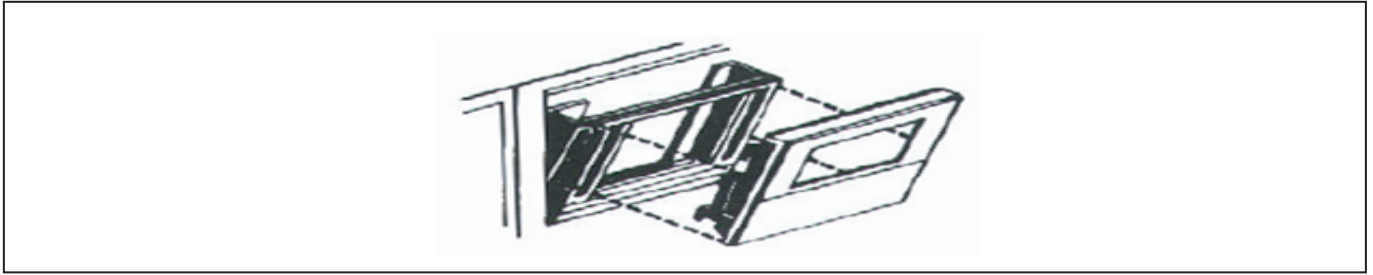

DEMAGNETIZING HEADS

Residual magnetism will gradually build up on the heads through continuous use and cause erasure of high frequencies and hiss. The heads and metallic parts of the tape path should be demagnetized after 20-30 hours of operation with a commercially available head de magnetizer. Be sure the cassette deck is turned off.

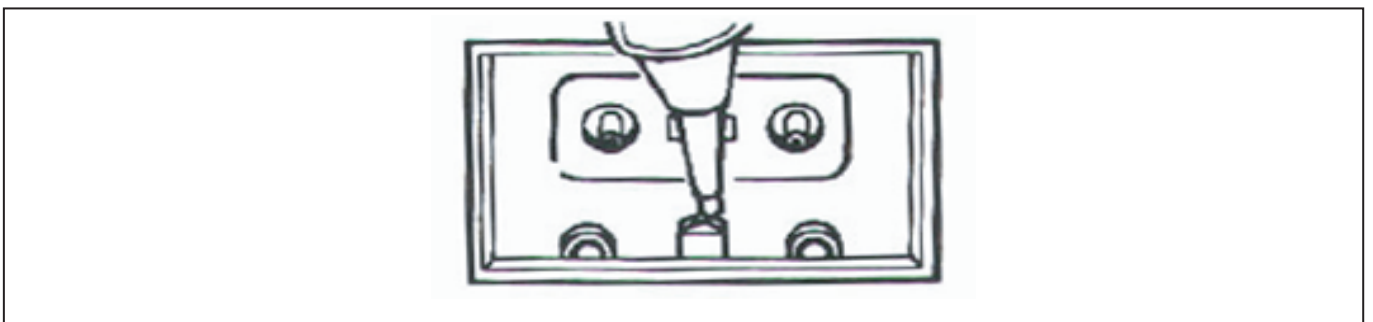

CLEANING CABINET

Clean the cabinet, panel and controls with a soft cloth lightly moistened with mild soap solution. Do not use any type of scouring powder or solvent such as alcohol or benzine.

Note on Cassette

TO PROTECT RECORDING FROM ACCIDENTAL ERASURE

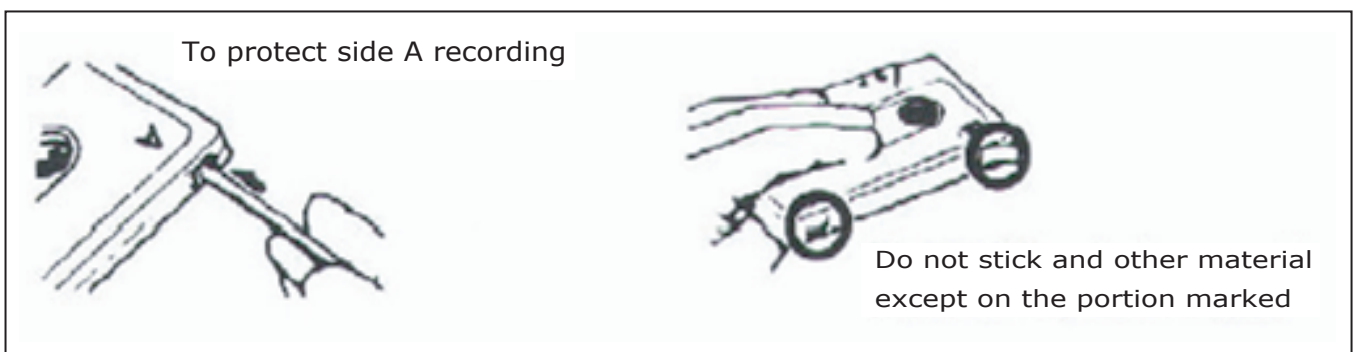

Remove the tab as illustrated so that the REC cannot be activated. To record on a cassette after tabs have been removed, simply cover the slot with cellophane or vinyl tape.



Unpacking and Installation

Although it is neither complicated to install nor difficult to operate your set , a few minutes of your time is required to read this manual for a properly wired installation and becoming familiar with its many features and how to use them.

Please take a great care in unpacking our set and do not discard the carton and other packing materials. That may be needed when moving your set and are required if it ever becomes necessary to return your set for service. Never place the unit near radiators, in front of heating vents, excessive humid or dusty location to avoid early damage and for your years quality use. Connect your complementary component as illustrated in the following page.

 <p>CAUTION RISK OF ELECTRIC SHOCK DO NOT OPEN</p>	 <p>This symbol is intended to alert the user to the presence of uninsulated "dangerous voltage" within the product's enclosure that may be of sufficient magnitude to constitute a risk of electric shock to persons.</p>
<p>CAUTION : TO REDUCE THE RISK OF ELECTRIC SHOCK. DO NOT REMOVE COVER (OR BACK). NO USER-SERVICEABLE PARTS IN SIDE. REFER SERVICING TO QUALIFIED SERVICE PERSONNEL.</p>	 <p>This symbol is intended to alert the user to the presence of important operation and maintenance (servicing) instructions in the literature accompanying the appliance.</p>
<p>WARNING To prevent fire or shock hazard, do not expose the unit to rain or moisture.</p>	<p>Caution : To prevent electric shock do not use this (polarized) plug with an extension cord, receptacle or other outlet unless the blades can be fully inserted to prevent blade exposure.</p> <p>Attentions : Pour prevenir les chocs electriques ne pas utiliser cette fuche polarisee avec un prolongateur, une prise de courant on une autre soruie de courant, sauf si les lames peuvent etre inserees a fond sans en laisser aucune partie a decouvert.</p>

MULTI P.A COMBINATION AMPLIFIER

■ How to operate Telephone Paging

– Telephone paging remote broadcasting system is used for when broadcasting in a long-distance apart from broadcasting equipments, and the broadcasting is possible by calling with a telephone, a mobile phone and a key-phone.

- ① If a dial tone rings over twice, it becomes connect.
- ② "If you hear the following line "Hello, This is the telephone paging remote broadcasting system. Please, enter the 4 digit password.", enter the set password. **(The initial password is 1234.)**
- ③ If you hear the following line "Press '1' to start broadcasting, press '2' to change the password, press '0' to end the broadcasting.", press "1" to start broadcasting and press "2" to change the password.
- ④ " If you hear the following line "Please begin broadcasting after the chimel press '0' when finished.", the broadcasting starts.
- ⑤ By pressing "0" after finishing the broadcasting, the broadcasting is ended.

■ How to operate REMOTE AMP (DRA-9600)

– The remote broadcasting is possible as synchronizing with a DRA-9600 remote amplifier.

- ① Connect with the remote amplifier.
- ② Connect with a speaker line by pressing the CHANNEL button of the broadcasting region.
(Change On/Off as pressing the CHANNEL button once)
- ③ To start the broadcasting, press the BROADCASTING button. After ringing the chime , the broadcasting is started.
- ④ When the broadcasting is finished, press the BROADCASTING button. After ringing the finish chime, the broadcasting is ended.

■ How to synchronize a Fire Receiver

- Fire Receiver Port of P-type Contact-type

- ① Connect the EM Contact terminal of the Fire Receiver or the Fire Perception with "+" and the GND terminal.
- ② If "+" and the GND terminal has been shorted as perceiving the fire, all broadcasting is end, and all of channel makes a siren and a shelter broadcasting line.

※ **Information : When occurring the fire, the restoration will be repaired by separating the Fire Contact terminal.**

– Fire Receiver Port of R-type Data-type

- ① Connect the Data Synchronization terminal of the Fire Receiver with RS485+, RS485- and GND terminal.
- ② If the Fire Data has been received by perceiving the fire, all broadcasting is ended, and all of channel makes a siren and a shelter broadcasting line.

※ **Information : When occurring the fire in Data-type, the restoration will be repaired when the Data Restoration Sign has been received.**

Application

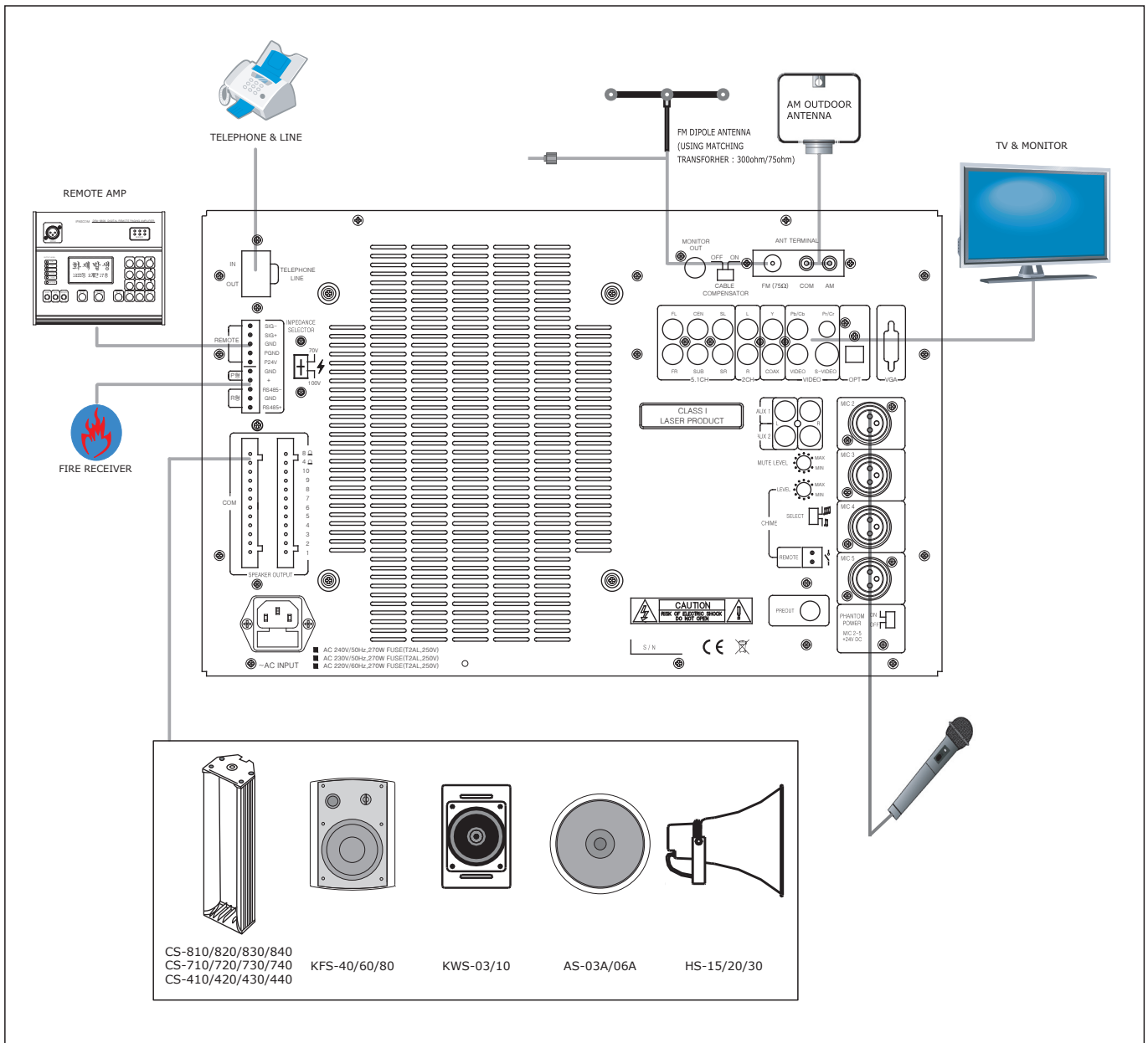

- Caution for the connection

- ☞ Use an outdoor antenna when a receiving state isn't good.
- ☞ Use a public antenna terminal in case of apartment or mass housing.
- ☞ You can also use as connecting an AM loop antenna simultaneously.
- ☞ Connect "+" to the Red terminal of speaker and "-" to the Black terminal of speaker.
- ☞ You should use the speaker PANDORA-1D/83Ω, PANDORA-2D/42Ω and PANDORA-3D/28Ω for this product when the voltage is 100V.

MULTI P.A COMBINATION AMPLIFIER

How to connect General TV.

◆ You should connect the product after shutting off (pull out the plug) the power of TV and PANDORA.

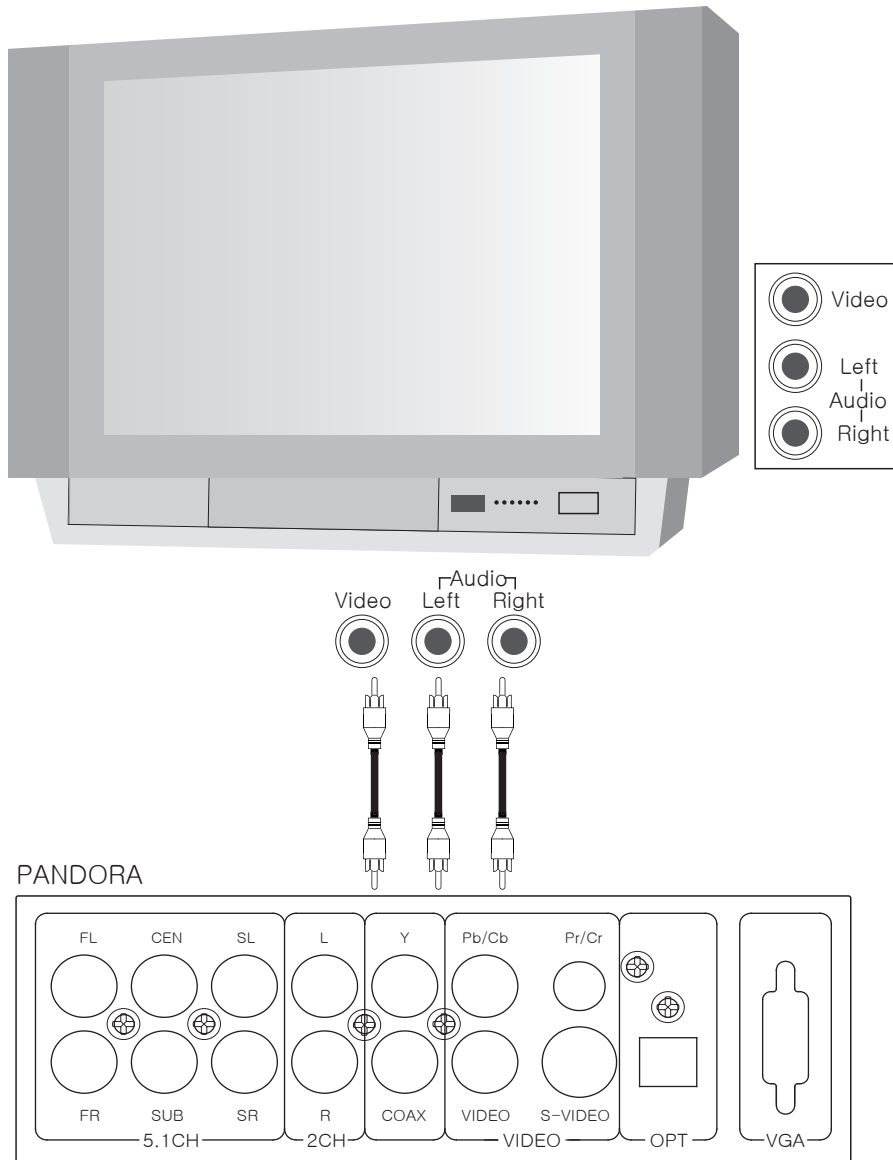

- ▶ Connect AV cables (Yellow, Red, White) to TV and the product as matching in color. In case the Sound is a mono, connect the Sound only one..
- ▶ Yellow cable is the Picture, connect it to the VIDEO terminal of PANDORA. Red cable is the Right Sound, connect the R terminal of PANDORA. Lastly, white cable is the Left Sound, connect the L terminal of PANDORA.
- ▶ After finishing the connection, switch TV to External Input, and then, switch to External Input by pressing the TV/External Input button of the TV remote control.
- ▶ You need a STEREO-RCA transfer gender when you connect the Sound Output to stereo channel 2 not to TV, and connect to the red terminal (MR), the white terminal (ML) of PANDORA. About the connection method of Channel 5.1, please refer to the special instruction book.

How to connect HD TV

- ◆ You should disconnect (pull out the plug) the power of TV and PANDORA while connecting cables.
- ◆ When you connect HD TV by a component, you must change the setting of Picture Output to Component. You can set in Set-up or use the V-MODE button of the remote control.

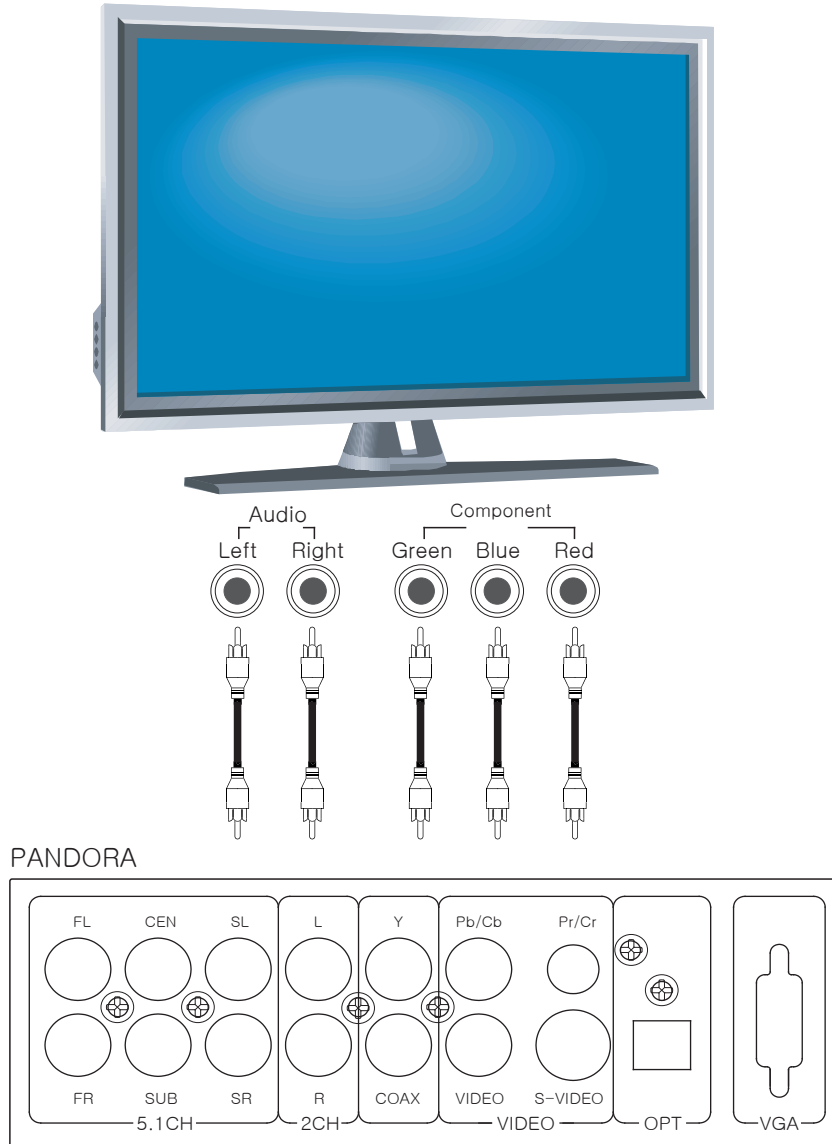

- ▶ Connect picture cables (Green, Blue, Red) to the component picture terminal of HD TV and the component terminal of PANDORA as matching in color. (Sound : L terminal [white], R terminal [Red])
- ▶ For the sound, connect AV cables in red, white to the component sound terminal (Red, White) and PANDORA.
- ▶ Finishing the connection, power on the HD TV and change the setting to "P-SCAN YPBPR" in System Set Up-Video of the set-up menu. If the picture sign doesn't come up, change to "P-SCAN YPBPR" using the V-MODE button of the remote control so that the picture is out-putted normally.

MULTI P.A COMBINATION AMPLIFIER

How to connect PC Monitor

- ◆ You should disconnect (pull out the plug) the power of a monitor and PANDORA while connecting cables.
- ◆ You must change the setting of the picture output to "PC-VGA" while connecting a PC monitor by VGA. You might set it in Set-up or use the V-MODE button of the remote control.
- ◆ Connect to VGA port of PCR using VGA cable.
- ◆ You should output the sound by a separate speaker or etc.

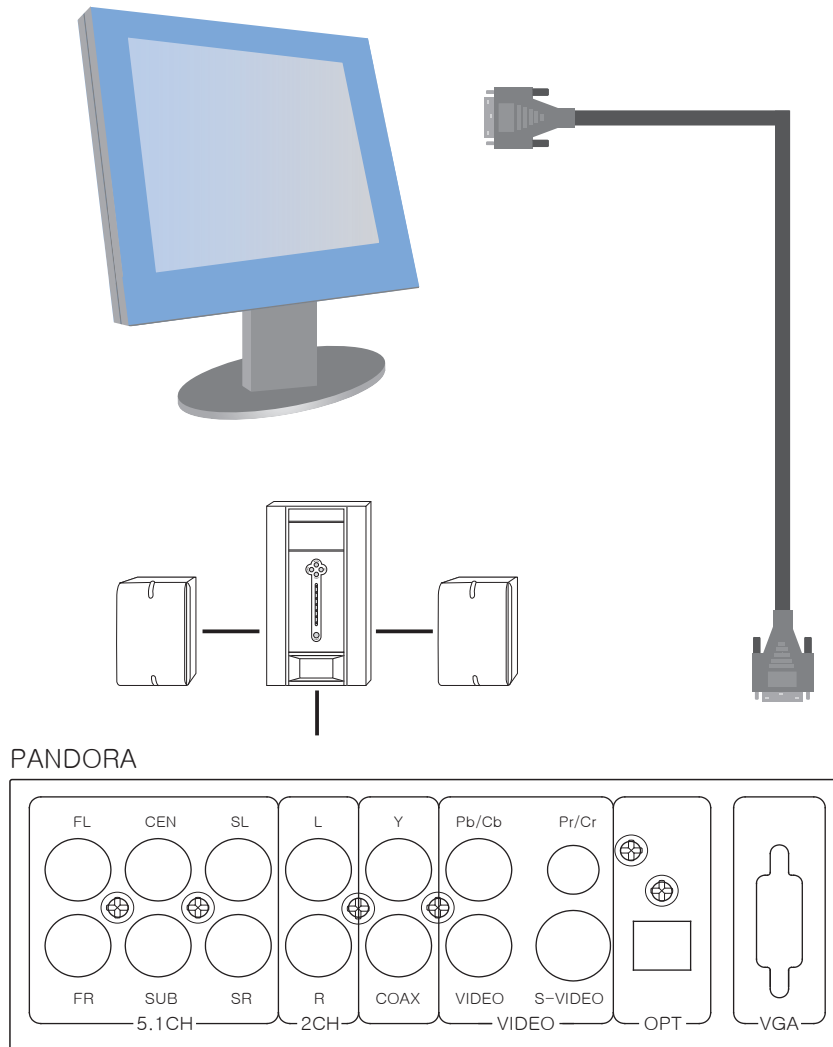

- ▶ Finishing the connection, power on the PC monitor and change the setting to "PC-VGA" in System Set Up-Video of the set-up menu. If the picture sign doesn't come up, change to "PC-VGA" using V-MODE button of the remote control so that the picture is out-putted normally.
- ▶ You need a STEREO-RCA transfer gender when you connect the Sound Output to the stereo channel 2 speaker for PC, and connect to the red terminal(MR) and the white terminal(ML) of PANDORA. About the connection method of Channel 5.1, please refer to the special instruction book.

How to connect the Channel 5.1 Analog System

◆ You should disconnect (pull out the plug) the power of a TV and PANDORA while connecting cables.

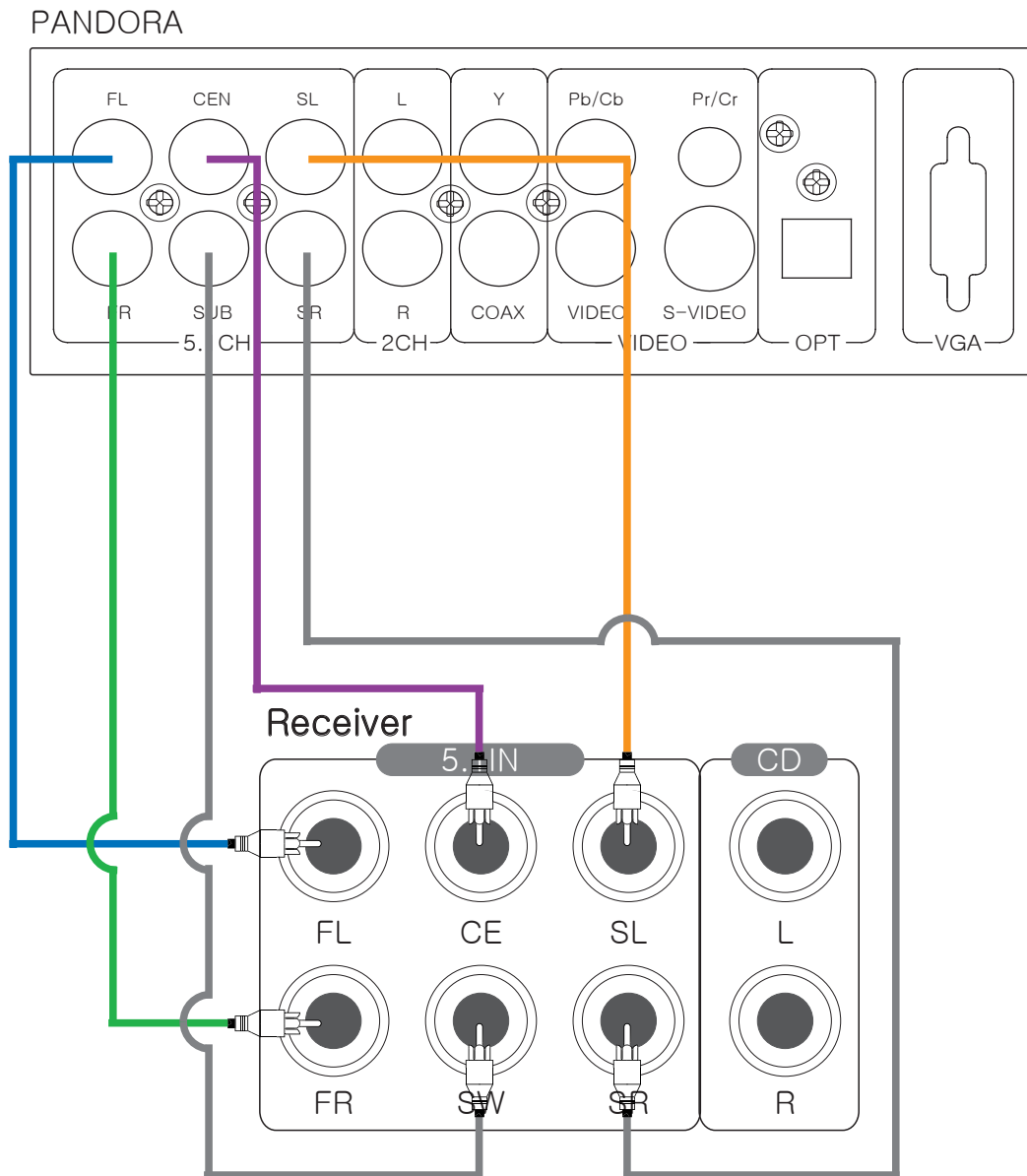

► When connecting the channel 5.1 analog sound card : The stereo output terminal of the sound card and the 5.1 IN input terminal

FRONT output terminal (Stereo) → Connect to each FR (Red), FL (White) terminal

SW/CEN output terminal (Stereo) → Connect to each SW (Red), CE (White) terminal

REAR output terminal (Stereo) → Connect to each SR (Red), SL (White) terminal

MULTI P.A COMBINATION AMPLIFIER

How to connect the Channel 2.1 System

◆ You should disconnect (pull out the plug) the power of a TV, PANDORA while connecting cables.

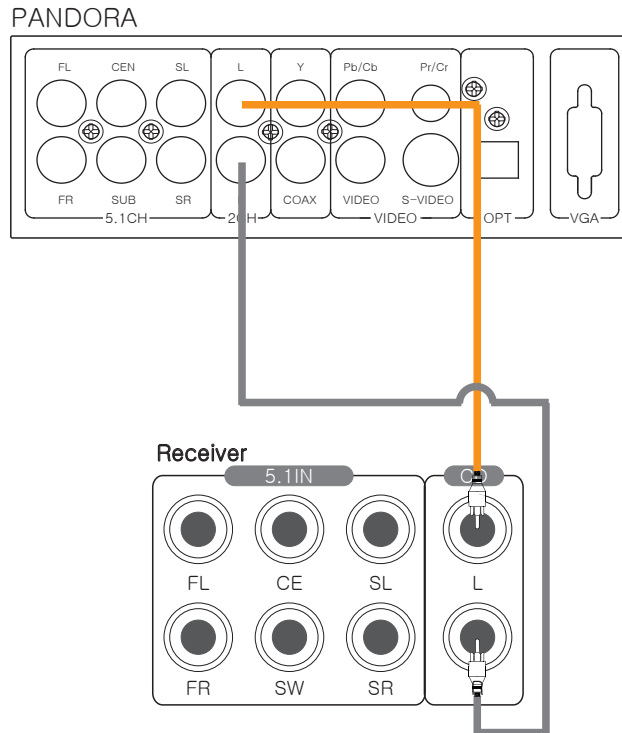

- ▶ The connection is possible with a gender or cable that changes a stereo jack of speaker to 2 of RCA (Red, White) terminals.
- ▶ When you watch a movie with the channel 2.1 or the channel 2 speaker, make the setting to stereography in Speaker Set Up–Mixed Mode of set-up menu.
- ▶ Channel 2 speaker can connect only the product which has an amplifier.

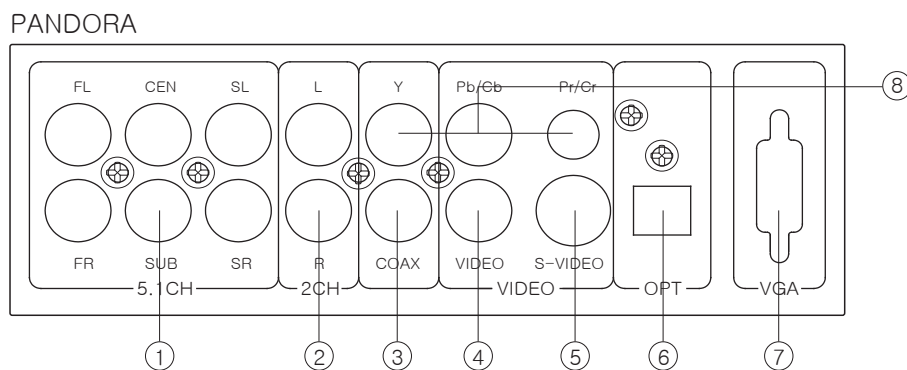

1. 5.1CH Analog Out
2. Audio Line Out
3. Digital Audio Out (Coaxial)
4. Video Out (Composite)

5. S-VIDEO Out
6. Digital Audio Out (Optical)
7. Video Out (VGA)
8. Video Out (Component)

Menu operation (System standard setting)

◆ The main screen is shown by pressing the SETUP button of the remote control.

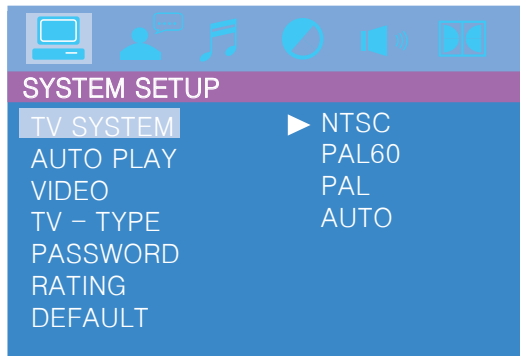

Set the TV type to NTSC.
PAL type is used in Europe or China.
If you select PAL, the black-white screen would be shown or the screen will be fuzzy and the screen color will not output normally as well.

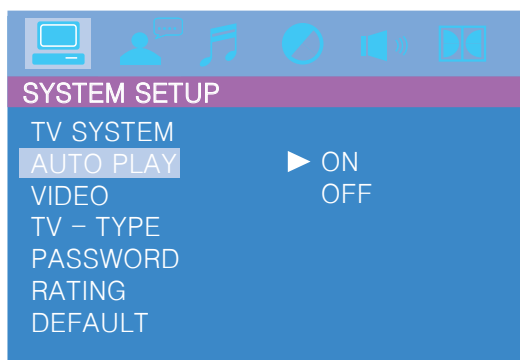

When you insert the DISC in the tray to play the DVD media, set OFF to stand by in DVD title(menu) and set ON to play DVD immediately.

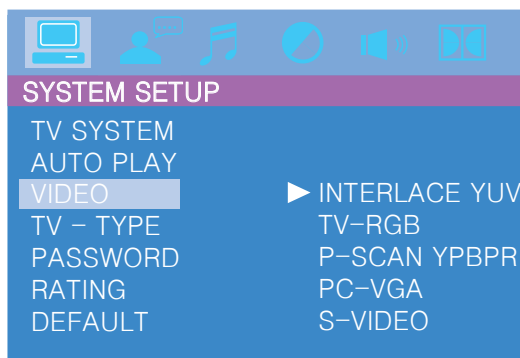

You must change to the picture output when making Component Output or VGA Output. It is possible to change using the V-MODE button of the remote control.

INTERLACE-YUV : Set it when making Component Output by HD TV for the export
TV-RGB : When connecting by a COMPOSIT cable
P-SCAN YPBPR : Set it when connecting by Component to HD TV
PC-VGA : Set it when outputting by a PC monitor.
S-VIDEO : When connecting by S-VIDEO

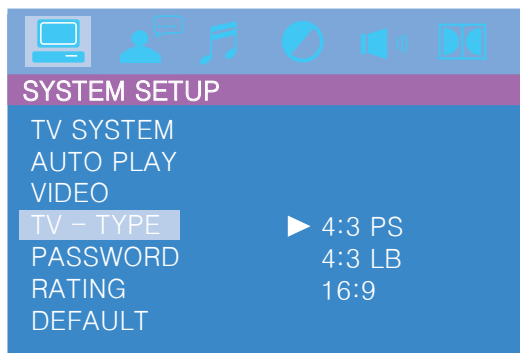

4:3PS : Set it when outputting by a general TV
4:3LB : The black-white screen might be shown when you output by a general TV.
You can watch with the full screen when you watch the movie that has a longer width than 16:9 during outputting by HD TV.
16:9 : Set it when outputting the wide screen such as HD TV and etc.

Menu operation (System standard setting)

◆ The main screen is shown by pressing the SETUP button of the remote control.

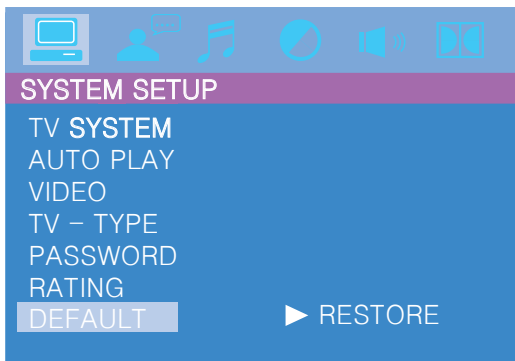
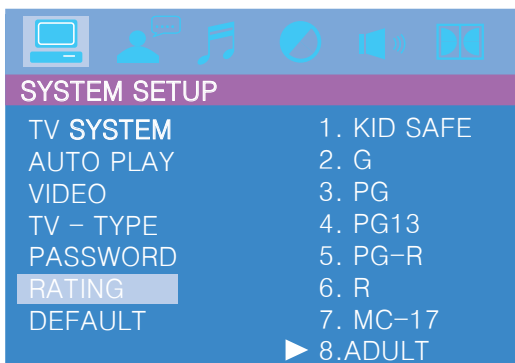
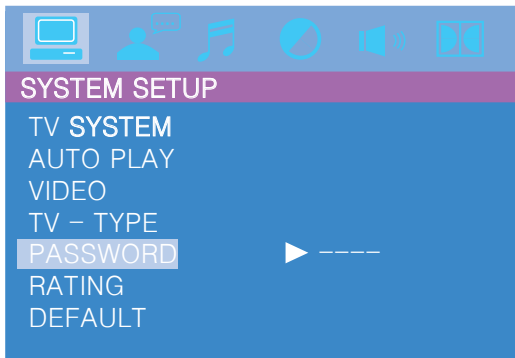

As a function to suggest the playback according to the grade of DVD, you don't need to use the password for the initialization. When using the password inevitably, the initial pin number is 0000. If you press 0000 after pressing ENTER on the password menu, you can select the grade menu, if you want playback of DVD without suggestion, select 8 grade.

★ This is only for DVD. Please make sure that it is impossible to reset if you forget the password after changing it. Therefore please use the product carefully and write down the password.

The grade is divided into grade 8 and it is the function only for DVD playback. The change is impossible if you don't enter the password.

★ The product is set by grade 8 when it is shipped.

Initialization

By selecting the Restore Order, all setting value is restored to the defaults.

After performing the Restore Order, you should reset.

Menu operation (Digital Set-up)

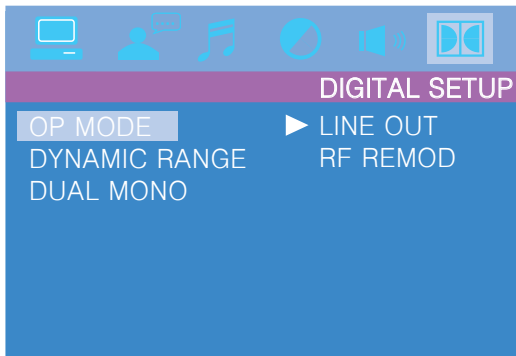

LINE OUT : It is a suitable setting to use at night and in low volume.

RF adjustment: It is a suitable setting to use in the anytime and in high volume.

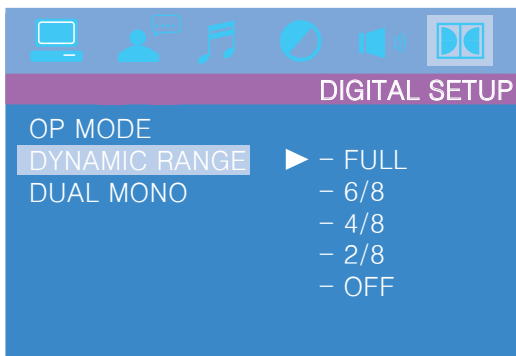

When playing the disc that is recorded by Dolby digital, you can hear the sound clearly in the low volume as condensing the dynamic range. It is possible to use when LINE OUT is selected in OP mode. You can hear the sound clearly as condensing the dynamic range when you set the Movement Range to FULL, if you set it "OFF", it plays without condensing the dynamic range.

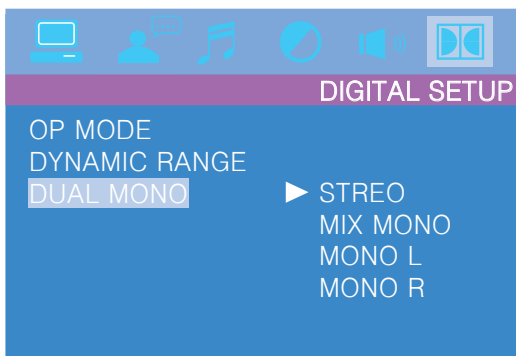

This menu is used for setting the L/R mono output and selecting the Karaoke mode. You can't use this function as this product doesn't provide the Karaoke function.

MULTI P.A COMBINATION AMPLIFIER

Menu operation (Language Setting)

◆ The main screen is shown by pressing the SETUP button of the remote control.



OSD Language
Select the language on the main screen.



AUDIO Language
This function comes under only for the playing DVD.
If there are several languages on DVD, you can select the right language.

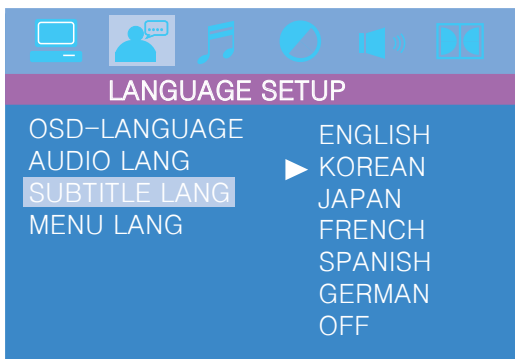

SUBTITLE Language
This function comes under only for the playing DVD.
If there are several languages on DVD, you can select the right language.

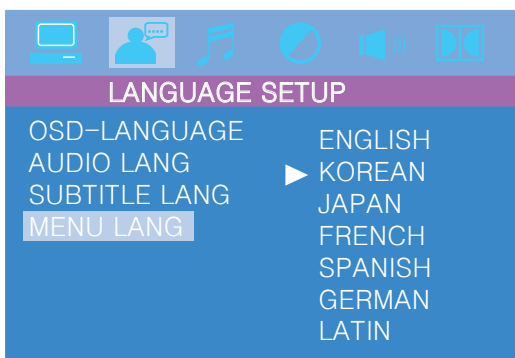

MENU Language
This function comes under only for the playing DVD.
If there are several languages on DVD, you can select the right language.

Menu operation (Audio/Video/Speaker setting)

◆ The main screen is shown by pressing the SETUP button of the remote control.

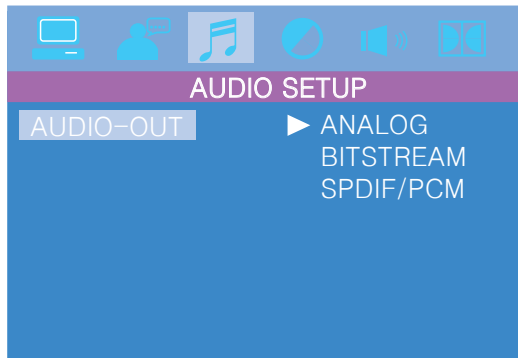

Audio-OUT

Analog : Select it only when using the stereo in right/left not using OPTICAL/COAXIAL as the output.
BITSTREAM : Use it when audio output by OPTICAL/COAXIAL or outputting by a speaker that has a built-in power amplifier or DTS decoder.
SPDIF/PCM : In case that is connected with Digital stereo amplifier of channel 2, it is converted and out-putted by PCM sign of channel 2 from an OPTICAL/COAXIAL jack.

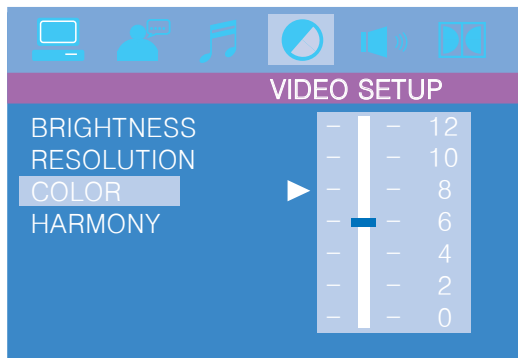

Brightness

The default is 6 and you can adjust the brightness. You can adjust by the Direction Key, the setting is completed by pressing "Enter" key.

Resolution

The default is 6 and you can adjust the resolution. Adjust it by the Direction Key, the setting is completed by pressing "Enter" key.

Color

The default is 6 and you can adjust the color. Adjust it by the Direction Key, the setting is completed by pressing "Enter" key.

Harmony

The standard value is 6 and you can adjust the harmony. Adjust it by the Direction Key, the setting is completed by pressing "Enter" key.

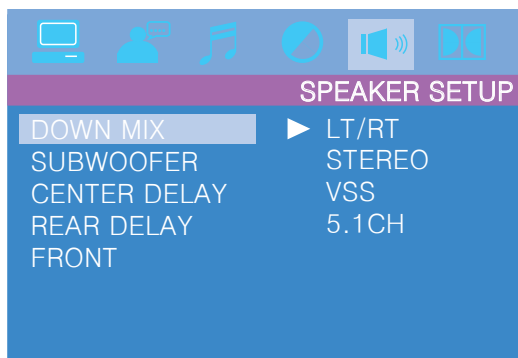

Down Mix

LT/RT : Select it when the disc has a built-in Dolby Prologic Effect.
STEREO : Select it when setting the stereo of channel 2.
VSS : Select it when you want to make a virtual Surround Sound Effect while playing the disc that is recorded by channel 5.1.
5.1CH : Select it when connecting the speaker of channel 5.1
Centering Delay : Adjust the centering delay time of the surround speaker.

Rear Delay : Adjust the rear delay time of the surround speaker.

MULTI P.A COMBINATION AMPLIFIER

SPECIFICATIONS

■ Rated Output	PANDORA-1D : 120W PANDORA-2D : 240W PANDORA-3D : 360W
■ Input sensitivity/Impedance	MIC-1 : 2.7mV/2.4k Ω , UNBAL MIC-2,3,4,5 : 2.7mV/2.4k Ω , BAL AUX-1,2 : 300mV/600 Ω , UNBAL REMOTE : 1V/600 Ω , BAL
■ Rated output/Impedance	PANDORA-1D : 70V/42 Ω , 100V/83 Ω PANDORA-2D : 70V/21 Ω , 100V/42 Ω PANDORA-3D : 70V/14 Ω , 100V/28 Ω
■ Frequency Response (+1/-3dB)	80Hz ~ 18KHz
■ T.H.D (@Rated Out, 1KHz)	Less than 1%
■ S/N(@30KHz LPF)	Better than 65dB
■ Power Source	AC 220V / 50Hz
■ Power Consumption	PANDORA-1D : 240W PANDORA-2D : 450W PANDORA-3D : 700W
■ Weight	PANDORA-1D : 16Kg PANDORA-2D : 23Kg PANDORA-3D : 30Kg
■ Dimensions	420(W) × 266(H) × 340(D) mm

※ Specifications and design are subject to change without notice for improvements.

